

PORTALE

Distinta e istruzioni

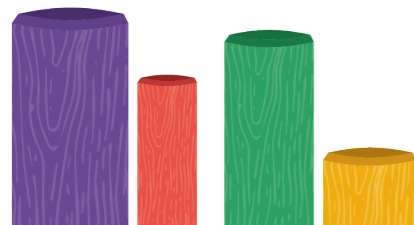
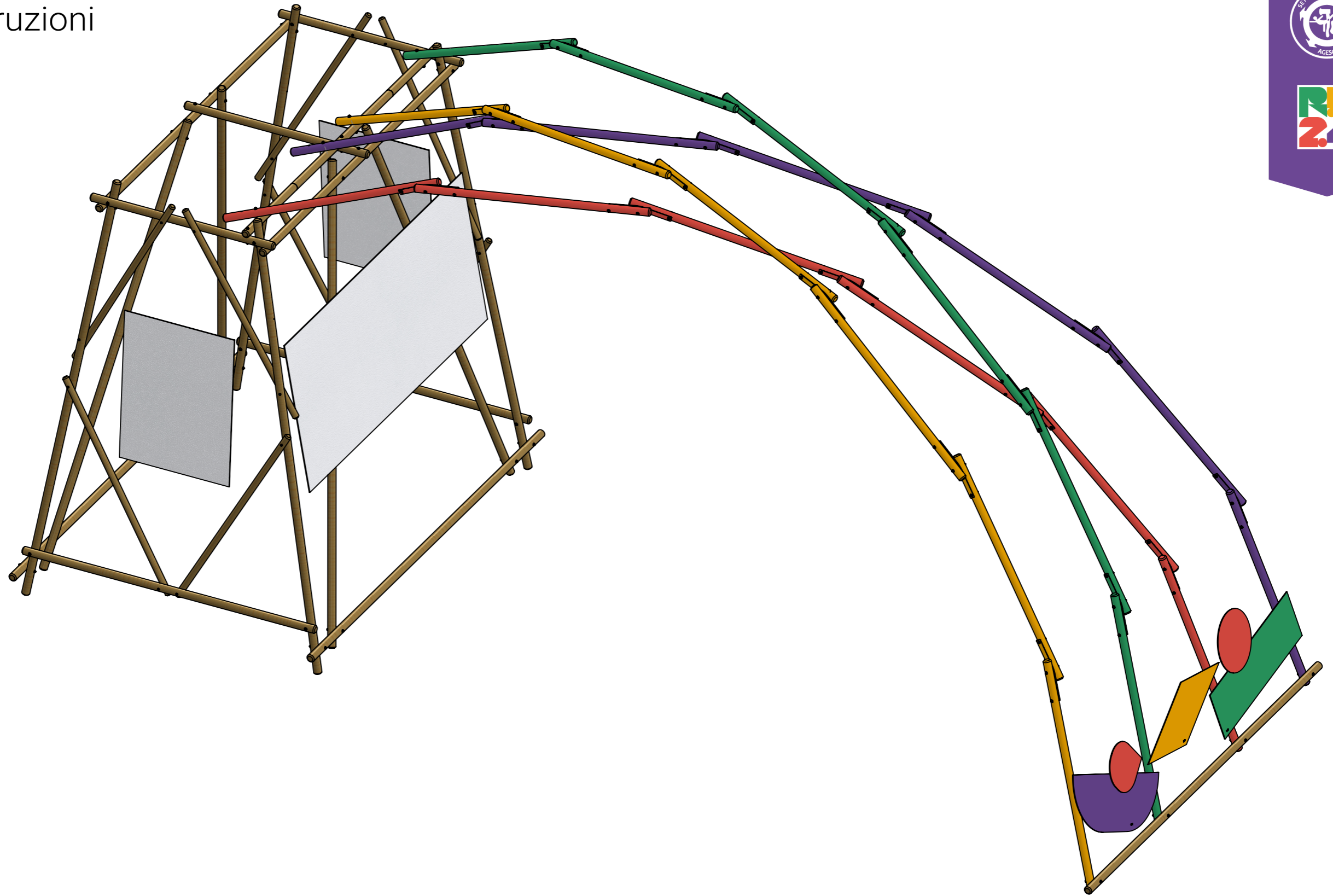

PORTALE

Misura Struttura

Le arcate vanno montate in modo che **i 4 incroci siano imbullonati** fra loro per conferire rigidità all'intreccio delle arcate. Il codice del bullone da usare è: 0100BUL037S M12x200mm. A meno dei due primi giunti a partire dal lato che appoggia a terra, tutti i giunti hanno un $\pm 3^\circ$ di regolazione per ogni palo, in modo da riuscire a modellare le arcate e fissare le intersezioni.

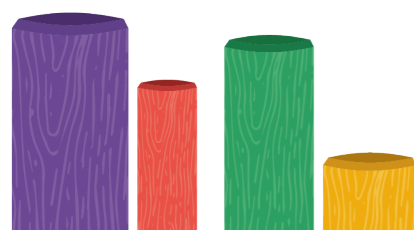
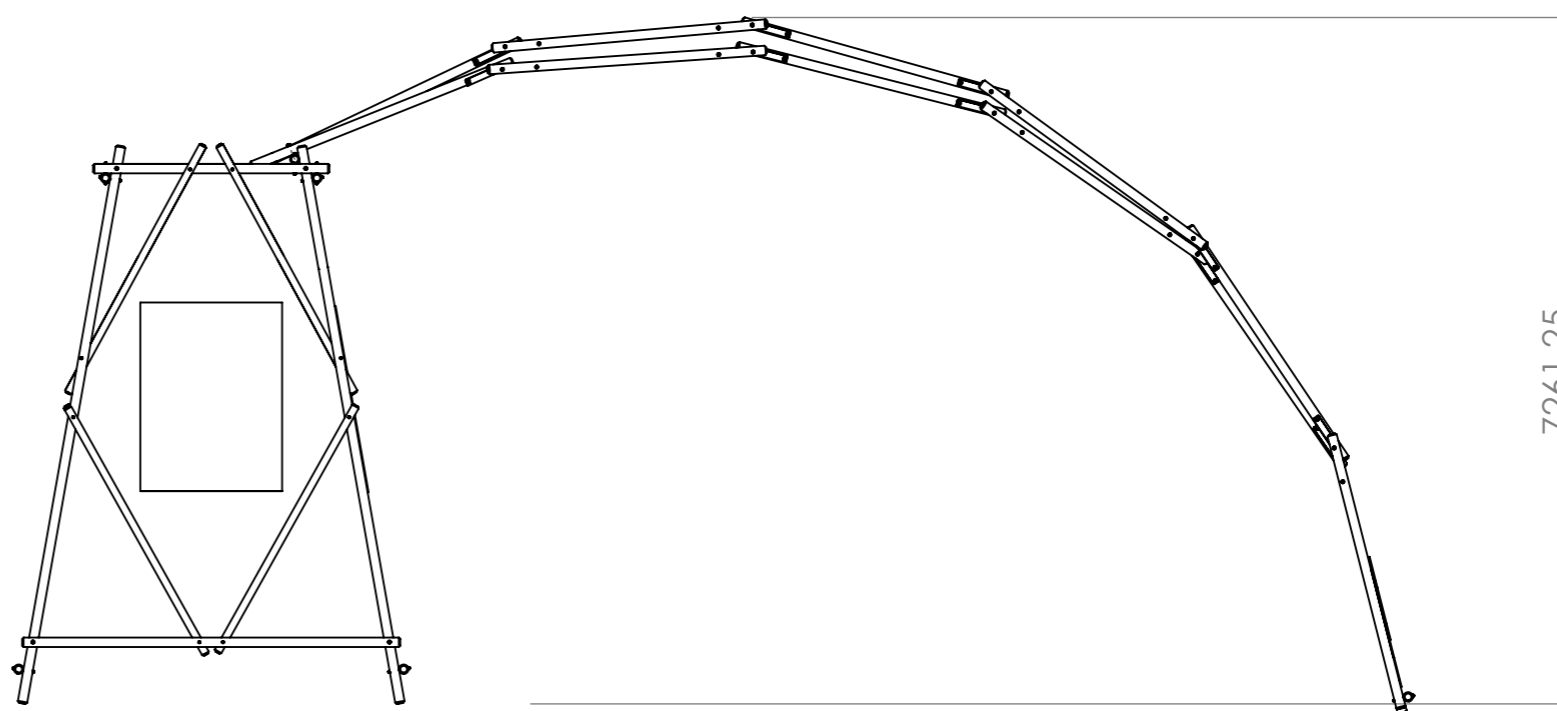
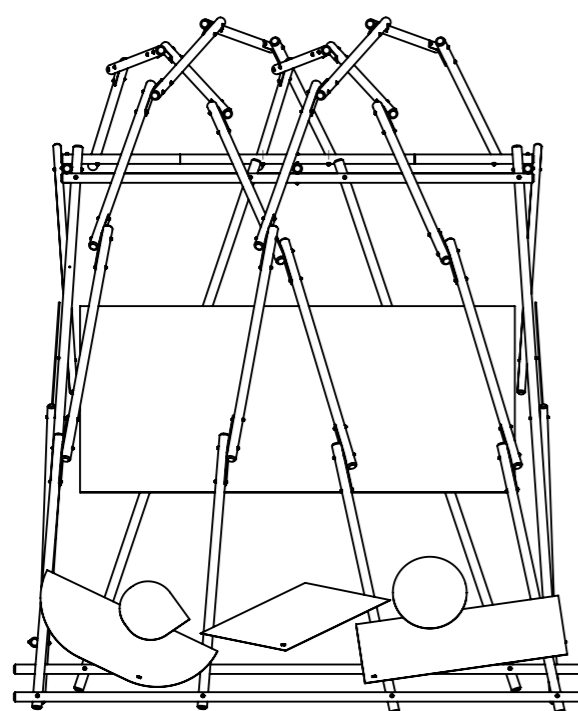
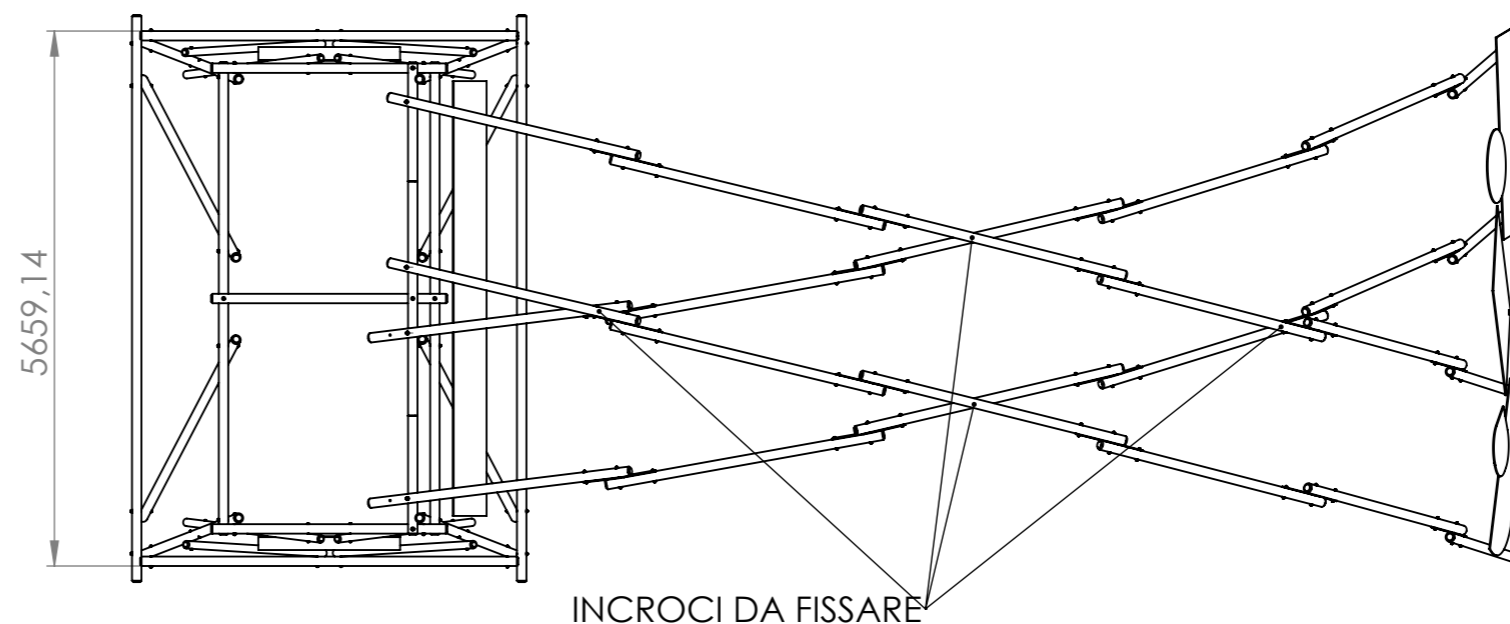

TORRETTA

Distinta e materiali

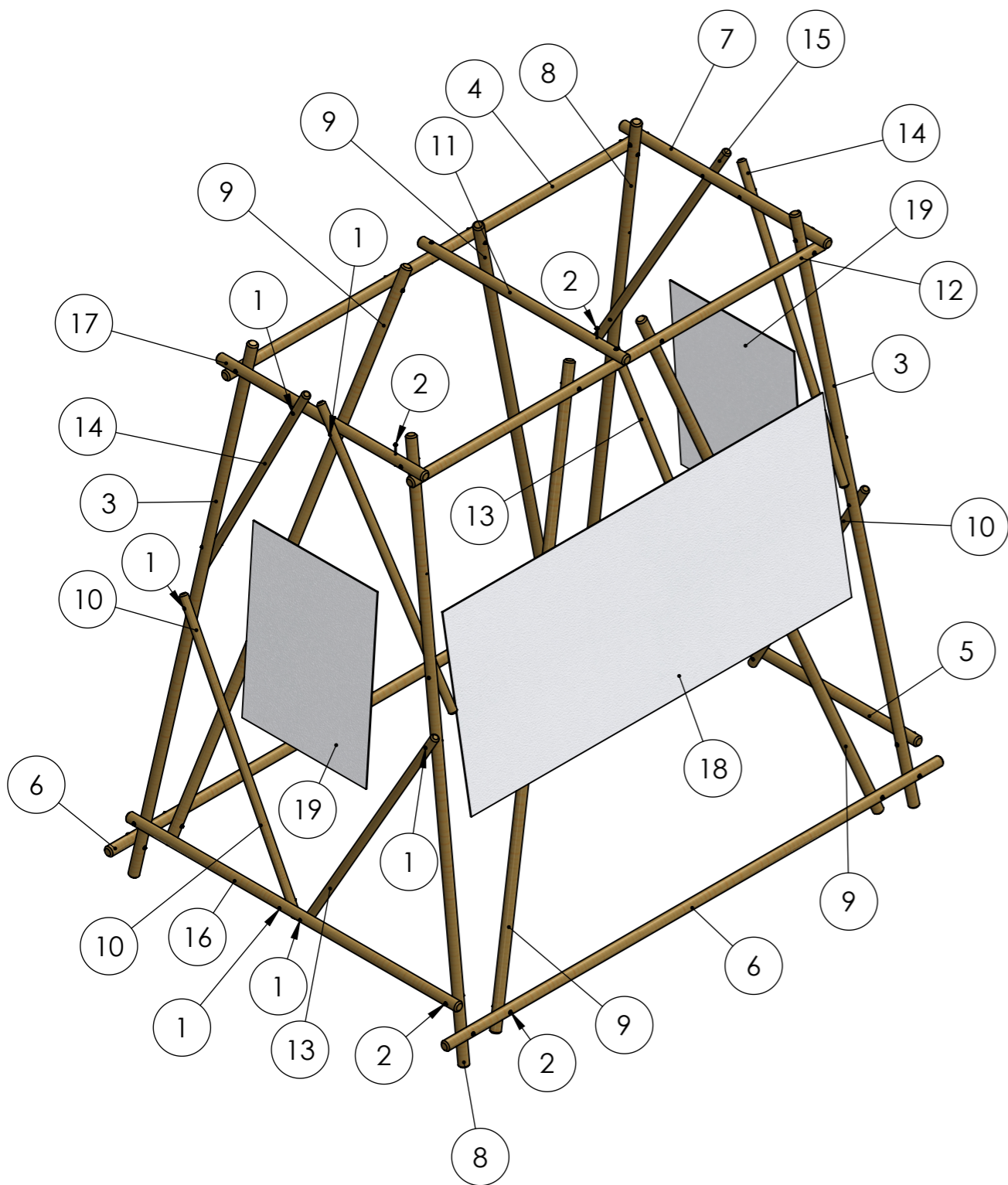

Num. articolo	Codice	Descrizione	Lunghezza	Diametro	Massa (gr)	Quantità
1	0100BUL014S	Bullone M10*180mm	205	10	164.04	16
2	0100BUL037S	Bullone M12*200mm	235	12	273.47	29
3	0206PAL000S	Palo 6000*100mm	6000	100	27448.25	2
4	0206PAL001S	Palo 5000*100mm	5000	100	22863.38	1
5	0206PAL002S	Palo 4000*100mm	4000	100	18288.02	1
6	0206PAL003S	Palo 6000*100mm	6000	100	27461.43	2
7	0206PAL004S	Palo 2500*100mm	2500	100	11395.44	1
8	0206PAL005S	Palo 6000*100mm	6000	100	27448.24	2
9	0206PAL006S	Palo 6000*100mm	6000	100	27479.37	4
10	0206PAL007S	Palo 3000*80mm	3000	80	8771.58	2
11	0206PAL008S	Palo 2500*100mm	2500	100	11408.62	1
12	0206PAL009S	Palo 5000*100mm	5000	100	22863.38	1
13	0206PAL010S	Palo 3000*80mm	3000	80	8771.58	2
14	0206PAL011S	Palo 3000*80mm	3000	80	8771.59	2
15	0206PAL012S	Palo 3000*80mm	3000	80	8771.59	2
16	0206PAL016S	Palo 4000*100mm	4000	100	18288.02	1
17	0206PAL019S	Palo 2500*100mm	2500	100	11395.44	1
18	0506BNR000S	Banner Principale Portale	4600*2000mm			1
19	0506BNR001S	Banner Laterale Portale	1500*2000mm			2



TORRETTA

Misura dei Componenti

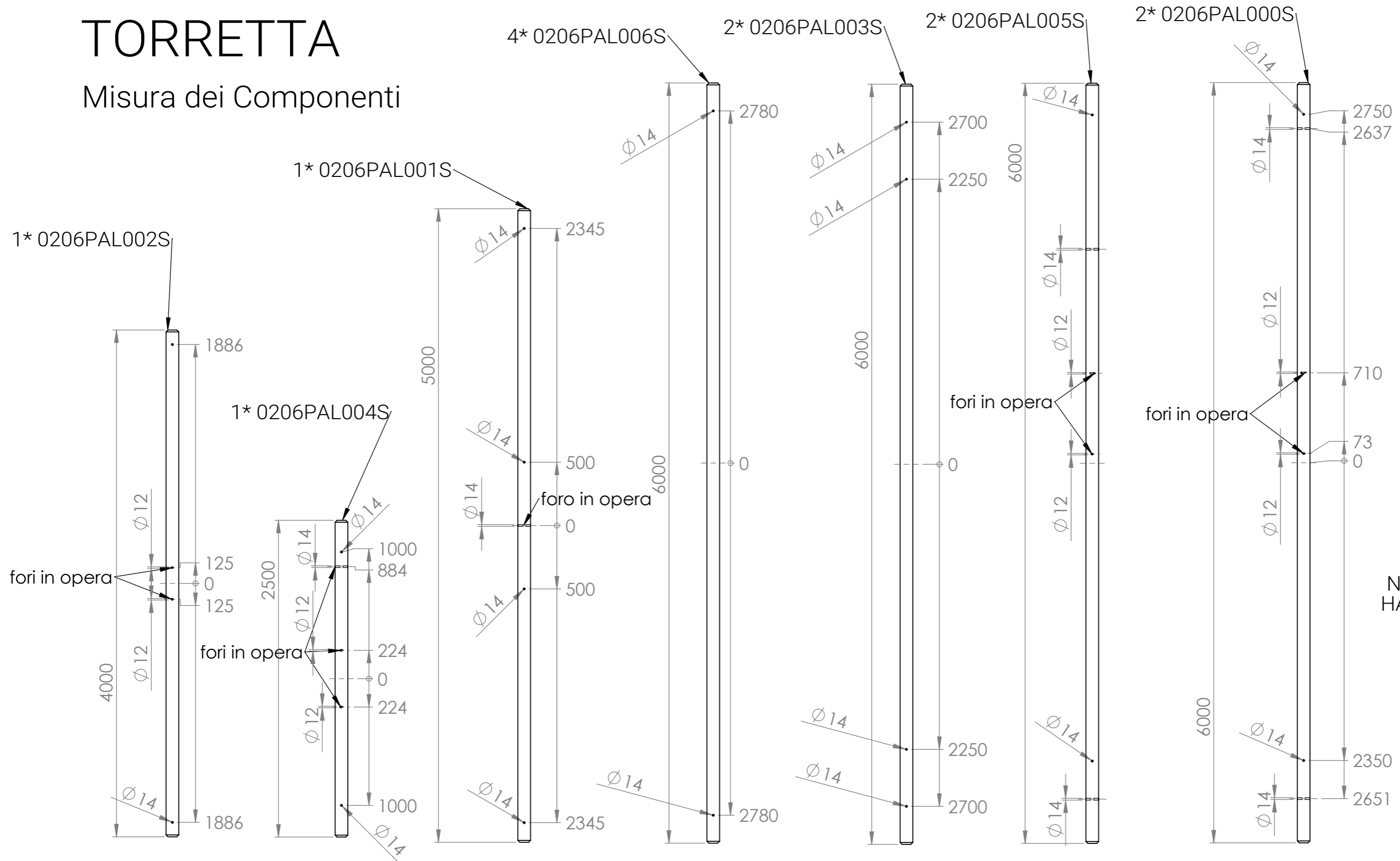

ATTENZIONE!!
NON TUTTI I FORI
HANNO DIAMETRO
14mm



ARCATE

Distinta e materiali

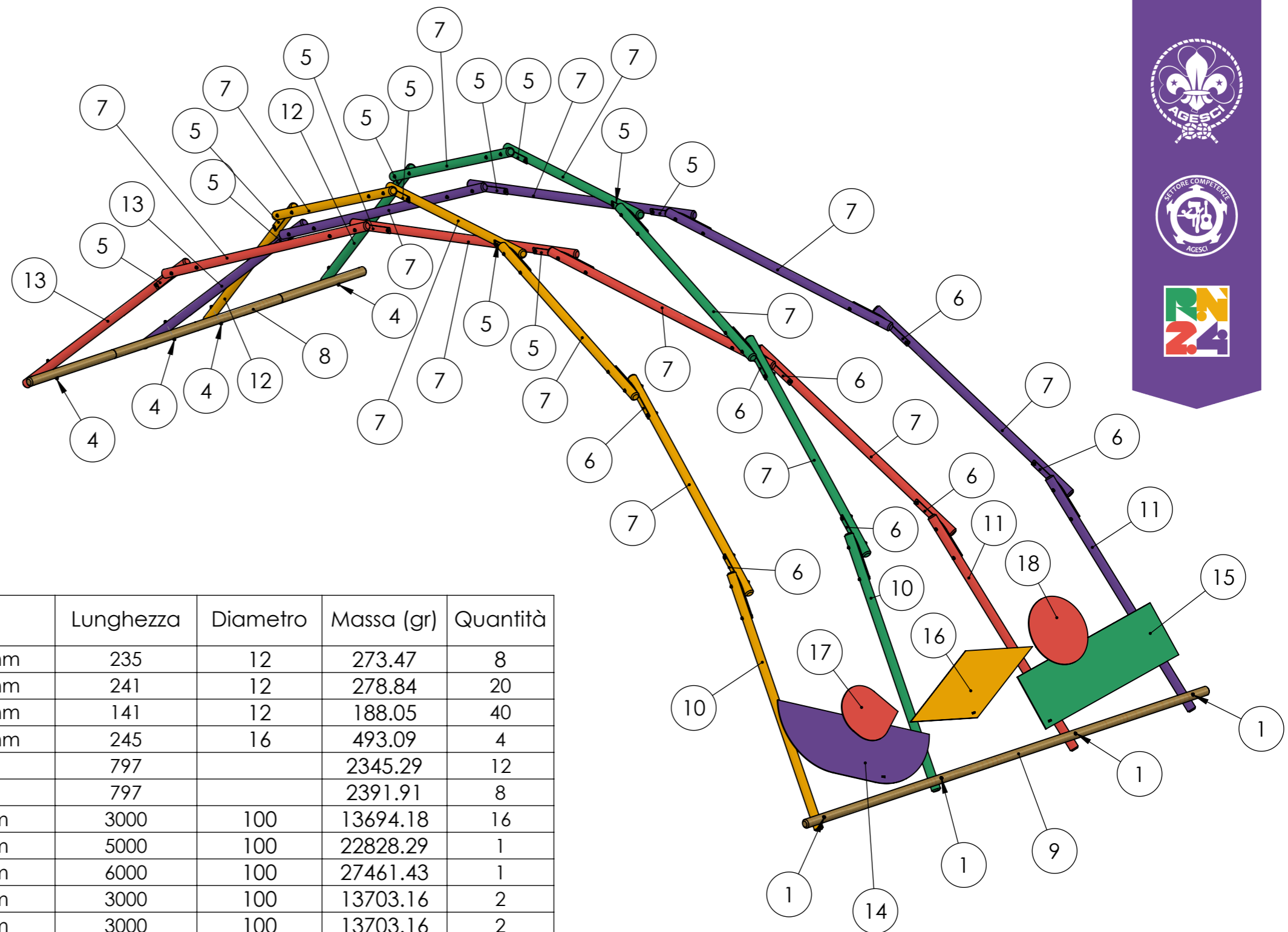

Num. articolo	Codice	Descrizione	Lunghezza	Diametro	Massa (gr)	Quantità
1	0100BUL037S	Bullone M12*200mm	235	12	273.47	8
2	0100BUL040S	Bullone M12*206mm	241	12	278.84	20
3	0100BUL041S	Bullone M12*106mm	141	12	188.05	40
4	0100BUL047S	Bullone M16*200mm	245	16	493.09	4
5	0106GNT000S	Giunto	797		2345.29	12
6	0106GNT001S	Giunto Fisso	797		2391.91	8
7	0206PAL013S	Palo 3000*100mm	3000	100	13694.18	16
8	0206PAL014S	Palo 5000*100mm	5000	100	22828.29	1
9	0206PAL015S	Palo 6000*100mm	6000	100	27461.43	1
10	0206PAL017S	Palo 3000*100mm	3000	100	13703.16	2
11	0206PAL020S	Palo 3000*100mm	3000	100	13703.16	2
12	0206PAL021S	Palo 3000*100mm	3000	100	13698.92	2
13	0206PAL022S	Palo 3000*100mm	3000	100	13698.92	2
14	0206TGR000S	Forma Tangram 1			1912.75	1
15	0206TGR001S	Forma Tangram 2			2244.84	1
16	0206TGR002S	Forma Tangram 3			1123.86	1
17	0206TGR003S	Forma Tangram 4			520.54	1
18	0206TGR004S	Forma Tangram 5			766.74	1

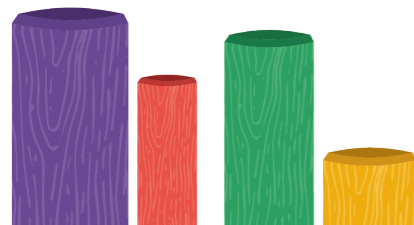

ARCATE

Misura dei Componenti

ATTENZIONE!!
NON TUTTI I FORI
HANNO
DIAMETRO 14mm

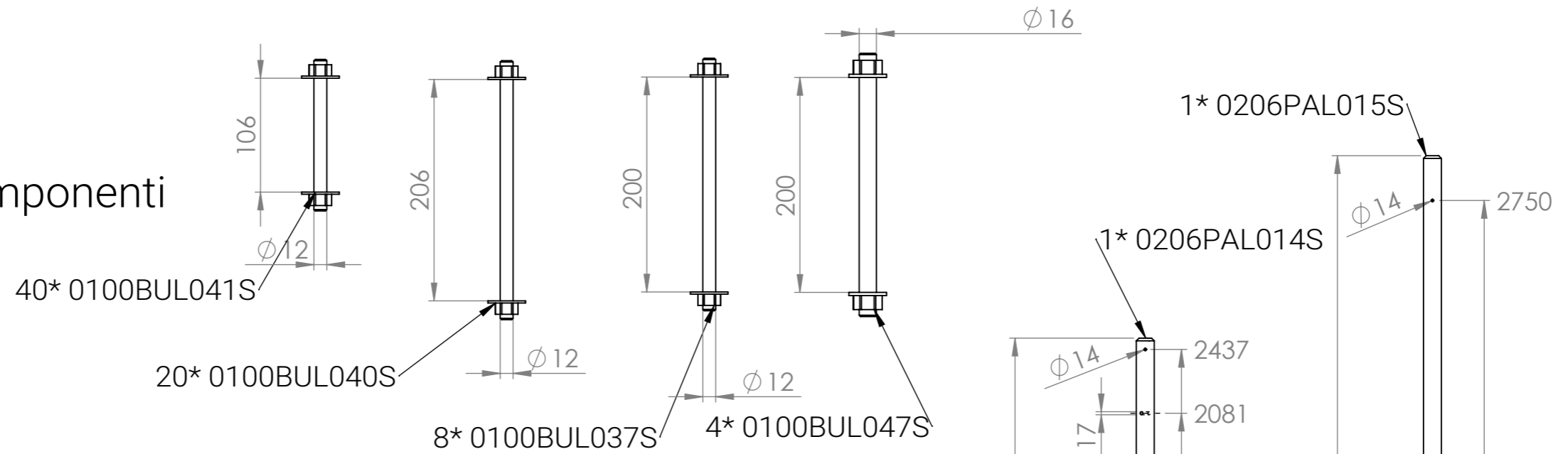

CHIAVI INGLES
DA 19 e 24 mm

